



→ Passenger lift for midibuses and coaches

## DH-CH.100-103 • 350 - 500 kg



The DH-CH100...103 are **heavy duty cassette lifts**, to assist wheelchair passengers to embark or disembark the midibus or coach in optimum safety.

The various lifts in this range are specially designed for particular mounting positions, under the chassis, in a compartment high above the ground (e.g. above wheel box), or integrated in the stairs at the access door.

The DH-CH100...103 are equipped with a firm, single-piece platform, eliminating as many components as possible (reduced maintenance).

# Robust, heavy duty cassette lifts with single-piece platform

## Weights [see pg. 15]

| Steel / Alu |        |
|-------------|--------|
| CH100       | 210 kg |
| CH101       | 295 kg |
| CH102       | 235 kg |
| CH103       | 270 kg |

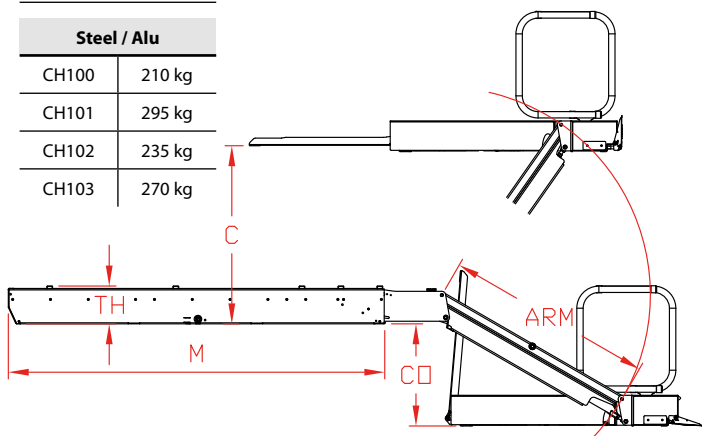

## Fitting dimensions

| Type           | ARM  | CAP       | CO max. | TH  | M    | C min. | C max. | K max. |
|----------------|------|-----------|---------|-----|------|--------|--------|--------|
| CH100          | 800  | 350       | 570     | 191 | 1917 | 530    | 590    | 1160   |
| CH100-M        | 1050 | 350       | 700     | 191 | 1917 | 660    | 780    | 1480   |
| CH101          | 1680 | 350 / 500 | 1250    | 205 | 2250 | 280    | 350    | 1600   |
| CH102 [S]      | 800  | 350       | 500     | 150 | 1995 | 290    | 680    | 1180   |
| CH102-OV [S]   | 1100 | 350       | 780     | 150 | 1995 | 190    | 400    | 1180   |
| CH103 [S]      | 1100 | 350 / 500 | 535     | 200 | 1995 | 380    | 940    | 1475   |
| CH103-1300 [S] | 1300 | 350       | 640     | 200 | 2195 | 530    | 1150   | 1790   |
| CH103-1280 [S] | 1280 | 350 / 500 | 600     | 200 | 1995 | 485    | 1135   | 1735   |

[S] = suitable for integration in the access stairs of the bus

## Technical specifications

|                                    |  |
|------------------------------------|--|
| Lift frame                         | 2 lift arms  |
| Cylinders                          | 2 lift cylinders   |
| Retraction in / out                | Electric motor + gear wheel system   |
| Type of ride [see pg. 8-9]         | Flat platform, level ride  |
| Standard platform dimensions       | 1200 x 800 mm (LxW)  |
| Platform details                   | <ul style="list-style-type: none"> <li>Aluminium platform with anti-slip coating</li> <li>Automatic roll-stop at the point</li> <li>Automatic bridge plate to the vehicle floor</li> </ul> |
| Safety rails                       | 2, left & right, folding manually  |
| Standard control unit [see pg. 10] | OAE001   |
| Standard finish of the lift frame  | KTL epoxy e-coating  |